

# DD 90

Tandem Vibratory Compactor

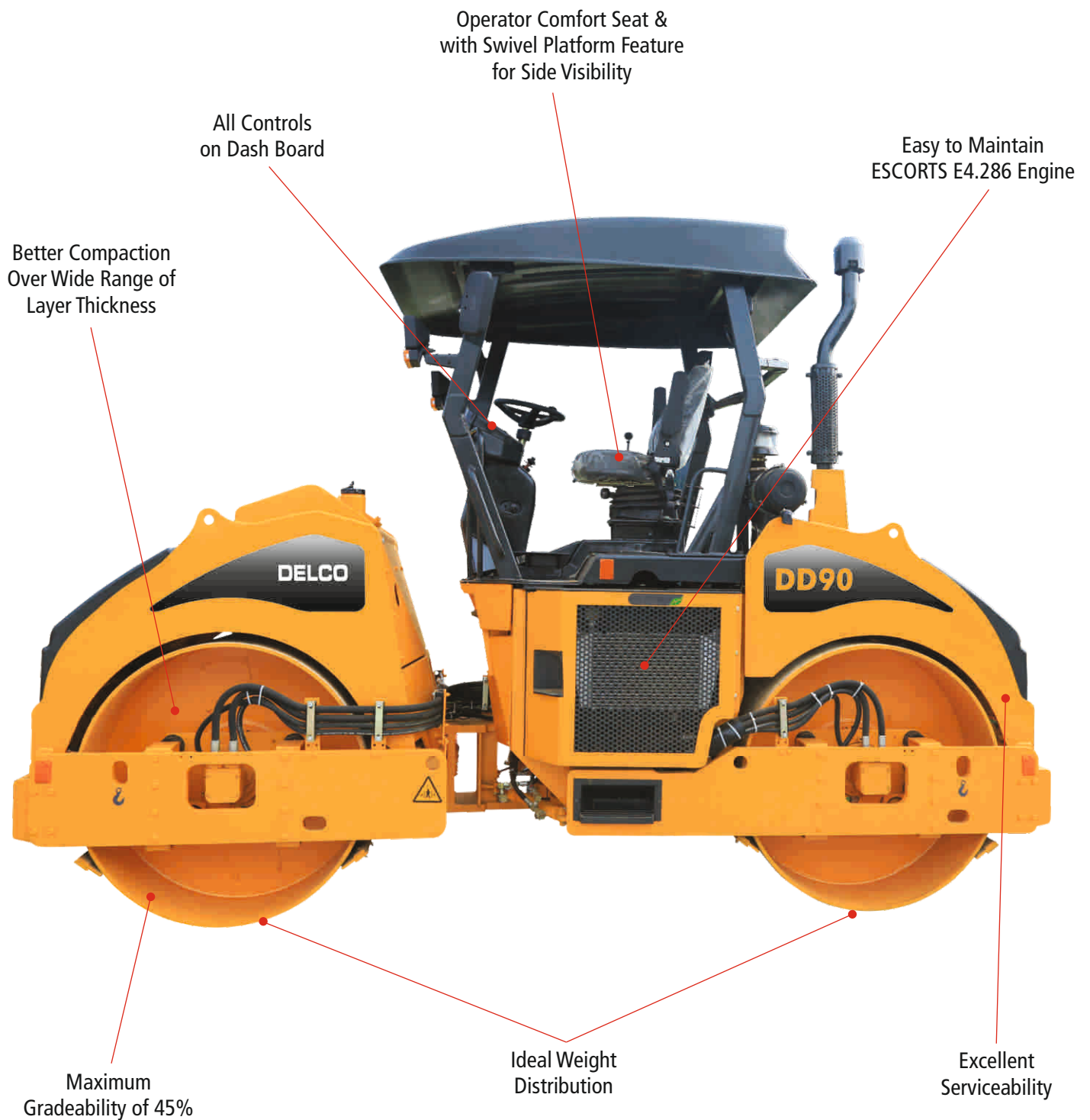

# DD 90

Tandem Vibratory Compactor

**DELCO**  
Built to Last

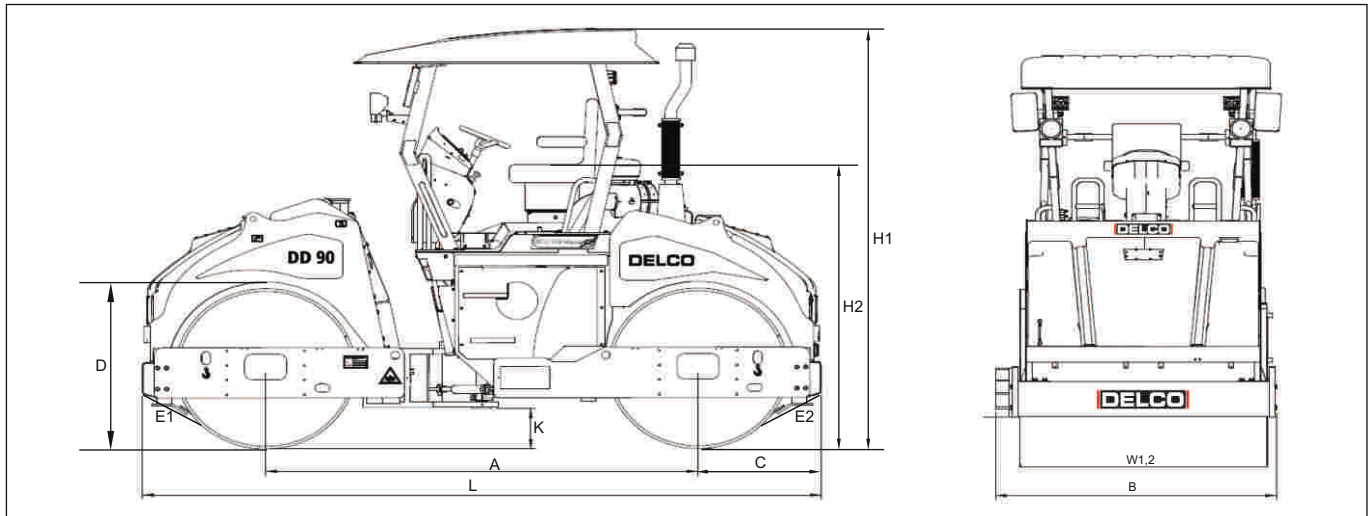

## TECHNICAL SPECIFICATIONS

Units	DD 90
<b>WEIGHTS</b>	
Maximum Operating Weight	Kg 9300
Operating Weight	Kg 9000
Weight On Front Drum	Kg 4500
Weight On Rear Drum	Kg 4500
Static Linear Load-Front	Kg/Cm 26.8
Static Linear Load-Rear	Kg/Cm 26.8
<b>DIMENSIONS</b>	
A	Wheel Base 2900 mm
B	Overall Width 1922 mm
C	Axle to Rear Face 820 mm
D1 = D2	Drum Diameter 1200 mm
H1	Total Travel Clearance with Canopy 3125 mm
K	Ground Clearance 310 mm
L	Total Travel Length 4550 mm
S	Drum Thickness 17 mm
W1 = W2	Drum Width 1680 mm
E1	Front Departure Angle 32°
E2	Rear Departure Angle 32°
<b>ENGINE</b>	
Make	ESCORTS E4.286 TCI
Specification	4 Cylinder, Water Cooled, Bharat Stage III Power 74HP @ 2300 rpm
Electrical System	12V
<b>VIBRATION SYSTEM</b>	
Frequency	Hz 33/50
High Amplitude	mm 1.0
Low Amplitude	mm 0.4
<b>SPEED</b>	
Travelling Speed	Km/hr 0-9.5

Units	DD 90
<b>GRADEABILITY</b>	
Gradeability Without Vibration	% 45
Gradeability With Vibration	% 30
<b>STEERING (Hydrostatic Power Steering)</b>	
Steering Angle	±30°
Oscillation Angle	±10°
<b>BRAKES</b>	
Service Brake	Hydrostatic
Parking Brake	Spring Loaded Brake, Hydraulically Released on both drums
Emergency Stop	Spring Loaded Brake, Hydraulically Released on both drums
<b>TANK CAPACITY</b>	
Fuel Tank Capacity	Lts 140
Hydraulic Oil Tank Capacity	Lts 117
Water Tank Capacity	Lts 700

<b>SPRINKLER SYSTEM</b>
4 stage filtration pressure sprinkle, Foot Actuation (Manual), Interval (Automatic), Corrosion free plastic water tank on each drum.

<b>SAFETY FEATURES</b>
Neutral Start Switch, Air Filter Clog Indicator, Hydraulic Filter Clog Indicator, Reverse buzzer, Auto-Vibration & Sprinkle Cut off. Audio Visual alarm during high coolant temperature and low pressure to be added.

<b>STANDARD EQUIPMENT</b>
Swinging operator seat for better drum visibility, Tilttable Steering, Larger operator platform accessible from each side, Electric operator controls, FRP roof, Instrument Panel With a range of control instruments including hour meter & Light Equipment.

<b>OPTIONAL FITMENT</b>
Switchable to single/either Drum Vibration, Cabin, Heater, Demister, Edge Cutting and pressing Discs, Cold Start Kit.

Channel Partner