

SSL 175

Skid Steer Loader



- Maneuverability • Compactness • Agility • Power & Economy
- Simple Operation • Easy Maintenance • Versatility • Operator Safety and Comfort
- Reliability • Low Total Cost of Ownership

Compact but powerful... versatility at its best

SSL 175

Skid Steer Loader

DELCO

B u i l t t o L a s t

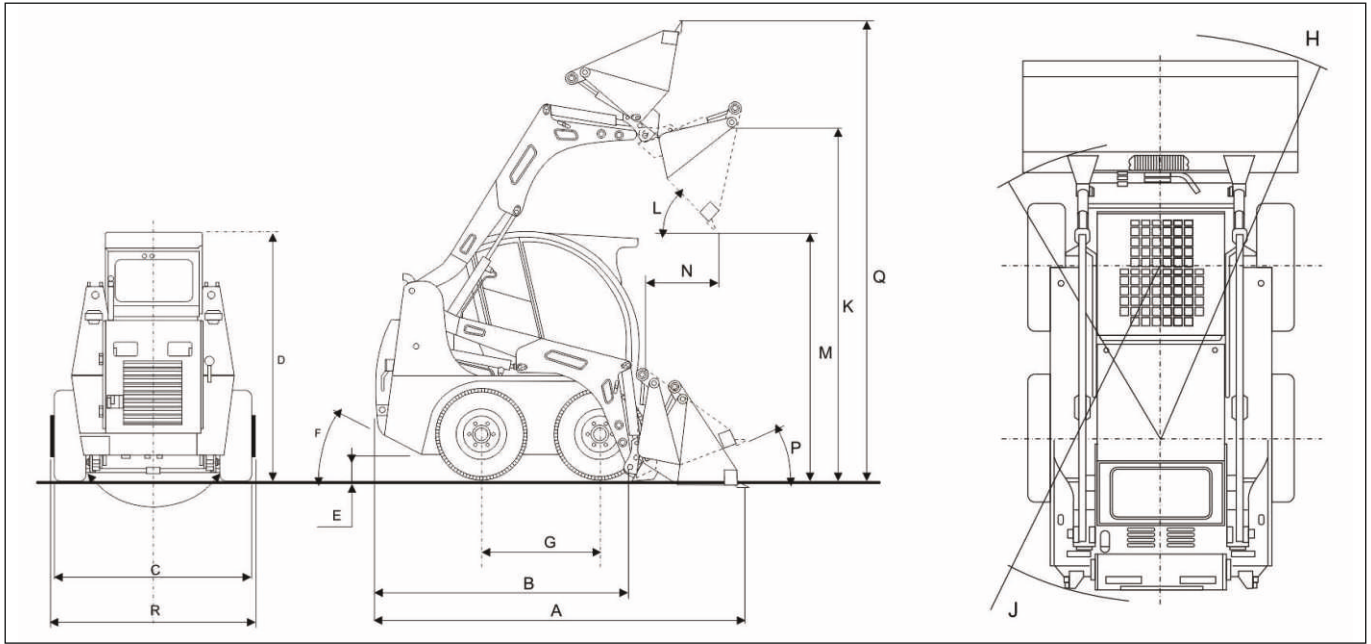

ENGINE

Simpson TSJ436 Industrial BS-BI 60HP, 2200 rpm, 4 Cylinder, Water Cooled Diesel Engine.

STATIC DIMENSIONS

	mm / deg
A : Length with bucket	3169
B : Length without bucket	2537
C : Width over tyres	1520
D : Overall height	2080
E : Ground clearance	210
F : Departure angle rear	26
G : Wheel base	1023
H : Turning radius rear corner	1530
J : Turning radius bucket corner	1930
k : Pin height	3022
L : Dump angle	41.5
M : Dump height	2275
N : Reach at dump height	642
P : Roll back at ground	28
Q : Max. reach at full height	3960
R : Bucket width (standard)	1650

TRANSMISSION

Hydrostatic 4x4 Independent Drive Through • Tandem Variable Displacement Axial Pumps • Fixed Displacement Low Speed High Torque Gerola Motors • Final Drive Through Positive Gear Boxes • Slip Free Drive Through Forged Gears.

BRAKES

Hydraulically activated and released multi-plate fade free brakes form integral part of drive motos.

PERFORMANCE

Rated operating capacity	750 kgs
Tipping load	1500 kgs
SAE operating weight	2776 kgs
Standard bucket capacity	0.46 cu.m
Maximum lift height	3022 mm
Time to raise lift arms fully	3.5 secs
Travel speed	upto 12 kmph
Turning radius	
Front corner	1930 mm
Rear corner	1530 mm
Ground clearance	210 mm
Departure angle rear	26 deg
Breakout force - bucket	1885 Nm
Breakout force - lift arms	1445 Nm

ELECTRICALS

12 volts negative earth system with battery isolator.

Battery: 150 AH, 1000 CCA, Low maintenance

Alternator : 60A

Starter Motor : 12V

State of the art, easy to read instrument console

CAPACITIES

Fuel system	62 ltr	Engine coolant	16 ltr
Engine lub. oil	9.5 ltr	Transmission	14 ltr
Hydraulic System	70 ltr		

HYDRAULICS

Engine driven gear pump with valve block, twin armslift cylinders with end cushion and dual bucket cylinders.

Flow : 83 litres per min, working pressure - 175 bar

Channel Partner